

# GATE APPLICATIONS

**RIXSON®**  
**ASSA ABLOY**

## Interior Gates

### 350 Gate Closer

- Maximum size 26" x 36"
- Maximum weight 75#
- Recommended for teller gates, office/courtroom rail gates, toilet partitions
- Includes top pivot and all mounting hardware
- Closing speed control
- Hold open field mount
- Minimum 6" from floor-surface mounted



### Duo Chek PH10/PH12 x AP3

- Maximum size 34" x 84"
- Maximum weight 125#
- Recommended for teller gates, office/courtroom rail gates, toilet partitions
- Includes top pivot and all mounting hardware
- Closing speed control
- PH10 hold open
- PH12 non-hold open
- Maximum 2" from floor



## Exterior Gates

### Offset Model SC27 or Center Hung SC28

- Maximum size 48" x 120"
- Maximum weight 350#
- Includes top pivot (for offset applications intermediate pivots are required, order separately)
- Closing and latch speed controls
- Adjustable hydraulic backcheck
- Sealed closer to resist elements
- CWF available for extremely cold environments
- Maximum 2" from ground



### 1350

- Maximum size 42" x 84"
- Maximum weight 150#
- Includes closer body, mounting brackets, arm and slide track
- Gate hanging means by others
- Mounts on cross member and gate post
- Closing and latch speed controls
- All weather fluid



### 1351

- Maximum size 54" x 120"
- Maximum weight 250#
- Includes closer body, mounting brackets, arm and slide track
- Gate hanging means by others
- Mounts on cross member and gate post
- Closing and latch speed controls
- Hydraulic backcheck
- All weather fluid
- Adjustable spring



# MODELS 1350 AND 1351

**RIXSON®**  
ASSA ABLOY

## Gate Closers with Sliding Arm

Extremely easy to install, these gate closers are particularly recommended for added safety and security of residences

- to prevent toddlers and pets from exiting pedestrian gates inadvertently left open
- to make sure that gates are closed at all times

### Features

- Two closing speeds independently controlled by thermostatic valves.
- Hydraulic backcheck (model 1351 only)
- Adjustable power (model 1351 only).
- Pinch free sliding arm and rail for safe use
- Soft opening and strong closing
- Suitable for gates with or without protruding bars
- Finish: black

### Installation

Closers 1350 and 1351 are supplied with all mounting screws and accessories. **No welding needed.**

### Specification

Surface gate closer mounted on post and slide track on gate.

## 1350

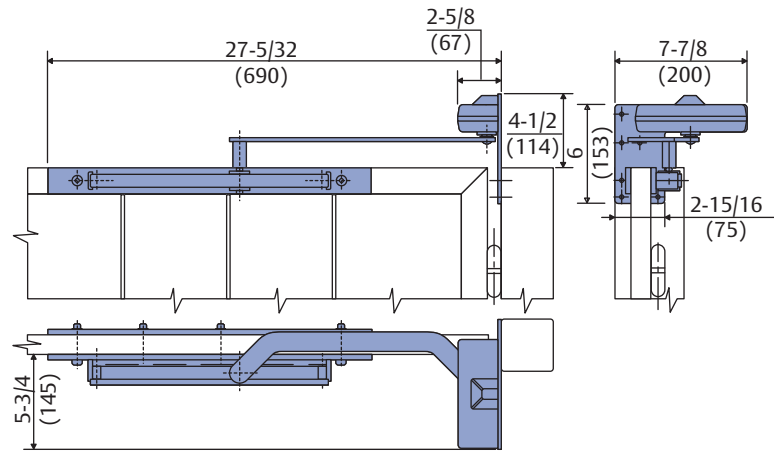

## 1351

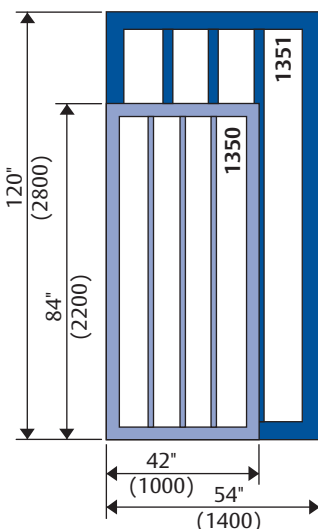
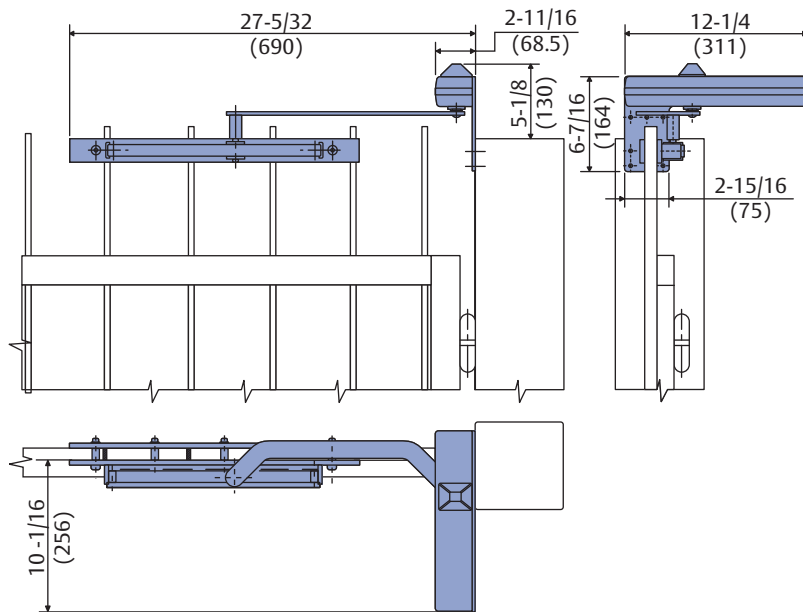

### Recommended Gate Size Limits:

- Model 1350: 42" (1,000mm) x 84" (2,200mm) x 150#
- Model 1351: 54" (1,400mm) x 120" (2,800mm) x 250#  
(for gates without panels)

For additional technical information contact Rixson Technical Support at 866-4RIXSON (474-9766). For pricing call your customer service representative 800-457-5670, or your local DSS representative.

Rixson • 9100 West Belmont Avenue • Franklin Park, IL 60131 USA • Tel: 800.457.5670 • Fax: 800.221.0489 • [www.rixson.com](http://www.rixson.com)

Rixson® and Rixson and Design® are registered trademarks of Yale Security Inc., an ASSA ABLOY Group company. Other products' brand names may be trademarks or registered trademarks of their respective owners and are mentioned for reference purposes only. These materials are protected under U.S. copyright laws. All contents current at time of publication. Copyright © 2008, Yale Security Inc., an ASSA ABLOY Group company. All rights reserved. Reproduction in whole or in part without the express written permission of Yale Security Inc. is prohibited. ASSA ABLOY is the global leader in door opening solutions, dedicated to satisfying end-user needs for security, safety and convenience.

44120-11/08R