

THE TECHNICAL NEWS MAGAZINE FOR THE SECURITY PROFESSIONAL  
**LOCKSMITH LEDGER**  
*International*



COMMERCIAL/RESIDENTIAL HARDWARE

# Selecting the Right Door Closer

**H**elping an owner, designer or architect determine what kind of door control hardware they need for their building is not as simple as selecting whatever closer you have on your shelf or in your truck. Many factors must be taken into account before you make your recommendations. You need to be aware of door construction, labeling, codes and environmental issues. We are going to try to put some of these in perspective so the next time you are asked to supply a door closer you will make an informed decision. The end result will be a satisfied end user who trusts your judgment.

Factors to consider, in order of importance, are: Fire/Life Safety, Handicap Accessibility, Aesthetics, Security and Convenience.

## FIRE/LIFE-SAFETY

It is essential that the locksmith be aware of fire codes and the kinds of doors you must supply in rated walls. These codes deal directly with life safety. When a building is on fire, the smoke is the major danger to lives in the building. An open door allows the spread of the suffocating blanket and noxious fumes.

Thirty years ago, who would have thought that our schools would need to have the ability to "lock down?" Specialized new lock functions can make that happen. But if an exterior door closer is not strong enough to close a door or does not have a latch speed control to ensure that the latch bolt engage, those special locks are useless.

## HANDICAP ACCESSIBILITY

Our world took a dramatic turn when legislation was passed that required a maximum of five pounds of opening force for interior doors.

Very often the resultant closing force may not be enough closing force to latch a door. Since fire-rated doors must close and latch, there is a conflict between code and law. Codes and common sense rule and even the Americans with Disabilities Act, admit that labeled openings are exempt...as are exterior doors.

## AESTHETICS

High profile buildings place a premium on aesthetics. How does the closer look relative to the entire door assembly? Some feel that a closer should be like a piece of jewelry. A plated closer cover and arm can be provided to match the exit

Door Operation Frequency Chart

Application	Daily	Yearly	
Large Department Store Entrance	5,000	1,500,000	HIGH
Large Office Building Entrance	4,000	1,200,000	
Theater Entrance	1,000	450,000	
School Entrance	1,250	225,000	
School Restroom Door	1,250	225,000	
Store or Bank Entrance	500	150,000	
Office Building Restroom Door	400	118,000	
School Corridor Door	80	15,000	AVERAGE
Office Building Corridor Door	75	22,000	
Store Restroom Door	60	18,000	
Residential Entrance Door	40	15,000	
School Janitor Closet	40	7,500	LOW
Residential Restroom Door	25	9,000	
Residential Hallway Door	10	3,600	
Residential Closet Door	6	2,200	

device or lever. Others are of the opinion that surface closers are unsightly. The designer will choose to conceal the closing mechanism in the header or the floor.

## SECURITY

The hardware professional must discover their client's preferences and provide the hardware that makes a safe, attractive door.

## CONVENIENCE

NFPA80 says a fire door cannot be held open mechanically. For convenience and traffic flow, the door must remain open. The solution is easy...make the hold open electromechanical, either in the closer or on the wall behind the door.

Never take convenience for granted.

## PERFORMANCE CRITERIA

The amount of traffic is pivotal in determining what kind and grade of closer to use. We will be talking more later about selection based on door usage.

## PERFORMANCE STANDARDS

Door closer manufacturers use American National Standards Institute (ANSI) to determine performance expectations. Remember that these tests are made in a controlled environment. Poor installation, weather and daily traffic can have a dramatic impact on the real capabilities of the product.

Looking at the performance criteria and the performance standards you can see that the door at your house coming from the garage probably wouldn't need an ANSI Grade 1 (or even 2) closer! Conversely, putting a Grade 3 closer on the main entry door to a mall is a huge mistake. Unfortunately, this one particular error happens every day.

**ANSI Grade 1:** 2 million w/o BC, 1.5 million w/ BC, Medium to High Traffic

**ANSI Grade 2:** 1 million w/o BC, 750,000 w/ BC, Low to Medium Traffic

**ANSI Grade 3:** 500,000 w/ or w/o BC, Low Traffic

## SWEEPING GENERALITIES

**Separate & Independent, Latch & Sweep Valves:** Regardless of the type of closing mechanism you use, surface or concealed, it is always a good idea to supply closers with separate checking and closing actions of the door.

The first thing you do is adjust the "closing" speed—sometimes this is called the "sweep" speed. This takes the door from full open to about 10 degrees.

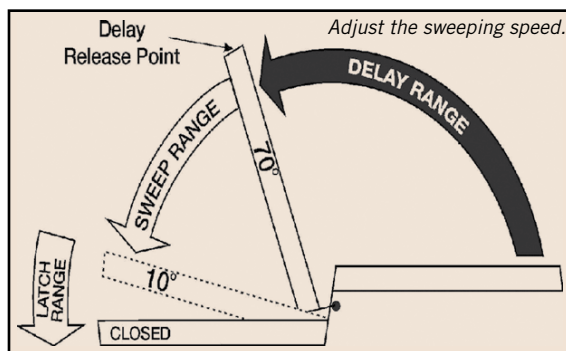

Next you will adjust the "latch" speed. This comes into play at 10 degrees to closed. This is an incredibly important factor. If you have a lock, with a latch bolt, on the door, you will adjust this to be faster than the sweep speed. By doing that you are giving the door an extra "kick" at the end of its closing cycle. That extra momentum at the end can mean the difference between a door latching, or not.

### Adjustable Hydraulic Backcheck:

At about 70 degrees in the opening cycle, there is another adjustment called "backcheck."

Backcheck slows the momentum of the door when it has been pushed or pulled open. It protects the door and frame. It is not a speed adjustment; it is an intensity adjustment. You can make backcheck hard or soft. You never want to make it so hard that it acts as a deadstop. This will shorten the life, of any closer, dramatically.

Backcheck is crucial in areas with strong winds or on closers without deadstops.

**Optional Delayed Action:** Another control valve that can be ordered as an option on a closer is delayed action. Delayed action comes into effect at 70 degrees and seems to hold the door there for a preset time period. The length of time is determined by the valve that you set. It can be short—as low as five seconds; or long—as much as a minute, in some closers.

Delayed action should not be used on exterior doors because building owners don't want their heating or air conditioning to be wasted every time someone walks through the door.

When you go into a building through a door that closes and locks behind you, you take comfort in the fact that you are in a safe haven. If you go into a building and the door remains open for 30 or 40 seconds, that haven isn't very safe, anymore. Anyone on the street can walk in behind you. This is a tremendous liability to the building owner.

If you must use this feature on interior doors, NEVER use them with a closer that has a hold open feature.

When you have a door held open and you want to close it, the door will stop at 70 degrees and stay there. We are a very impatient world and the very next thing you will do is grab the handle and pull the door to close it. Doing this will cause the seals to fail. You will know this is a bad thing when the oil starts running down the door!

The best safeguard is to not even offer delayed action to your customer.

## EFFICIENCY

Efficiency is a measure of the energy that is left over inside a closer to close the door, compared with the opening force. When you open a door, you are putting energy into the closer. To close the door, the closer must then unwind a spring – that is lost energy; the arm rotates on the spindle—that is lost energy; the elbow of the arm moves—more lost energy; the arm pivots on the frame—more lost energy.

Ten pounds of opening force will yield about six pounds of closing force.

Six pounds is really very good. Unfortunately, with ADA, we don't have the luxury of a 10-pound opening force...we only have five pounds. That means only three pounds of closing force remains. A latch bolt on a panic device requires five pounds of pull. Do the math...the door will never close.

Let's take the closer off of the door and put it in the floor.

A shallow depth floor closer uses a compression spring, just like a surface closer. So, the energy lost unwinding the spring is still lost. With a floor closer, the arm is attached to the underside of the door, making it a part of the door itself.

There is only one point of rotation—where the spindle moves. This means that there is not as much lost energy. With five pounds of opening force you will get about 4 pounds of closing force.

If you use the latch speed control on your closer, you have a good chance at getting the door to latch.

Some floor closers do not use a compression spring. They use a torsion spring which doesn't need to unwind. Obviously, these closers are even more efficient than the shallow depth type. With those products and latch speed adjustment, closing the door is assured.

## OPTIMIZE YOUR OPTIONS

Whether you are a seasoned veteran or just beginning to work with doors and hardware, you need to always understand the dynamics of different ways to close doors. The "one size fits all" mentality is fine for keeping inventories low. But, it is rarely the best thing for your customers. Stack pressure, weath-

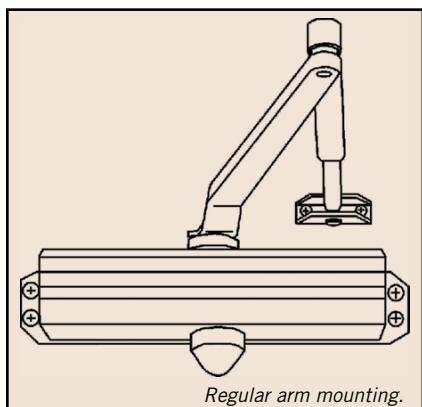

Regular arm mounting.

erstripping, gusty winds, high traffic all need to be addressed.

## APPLICATIONS

Regardless of whether you are talking about a surface closer or a concealed closer, the mounting has the greatest impact on function and efficiency.

Regular arm and top jamb mountings are the most efficient surface closer applications. Unfortunately, they are also the most prone to vandalism. An arm sticking out is just too tempting to walk past without wanting to tug on it. Putting these on schools would not be a very wise decision.

The regular arm is mounted on the pull side of the door, the top jamb on the push side.

The most common mounting for exterior doors is a parallel arm closer. It is also one of the most inefficient ways to close a door. Not only do you have the normal three points of rotation to use energy, now the arm needs to fold back. The good news is that they are less subject to abuse.

One big advantage to the parallel arm application is that can you get them with shock absorbing arms. This is an excellent way to protect the door and frame.

When you put a slide arm and track on a closer you have the most inefficient mounting of all. They give a much neater/cleaner "look" but, it comes at a cost on the function side.

If you are truly looking for a clean appearance, the best way to accomplish it is concealing the closer.

You can conceal the closer in the header. This can be accomplished by using models with slide tracks or centering arms. Just remember that when you use the slide track, you are affecting efficiency.

These closers are not only aesthetically appealing, they are not prone to vandalism...no missing covers or arms.

Exterior doors have a myriad of technical problems...weatherstripping, stack pressure, wind gusts, the need for lower opening forces to make them convenient to get through, vandalism, and high traffic. These doors require the most ef-

ficient closer possible. It needs to be out of harm's way; needs to have backcheck, latch and closing speed controls; needs to have deadstop and it needs to have 75-85 percent efficiency...it needs to be a floor closer.

## REPLACEMENT ISSUES

We all do replacement work. When you are replacing closers make sure that you:

Replace the product with the exact same quality. It needs to be the same ANSI Grade...or better (maybe it was not heavy duty enough and that is why you were called in);

Maintain building standards. Replace an overhead concealed closer with an overhead concealed closer, replace a floor closer with a floor closer. Now you can understand why they were installed in the first place!

We expect door closers to do a lot of things. They keep us safe from the elements and from disasters. They need to close the door fast but not too fast. Hold the door open and also close it.

Never underestimate their importance or take them for granted.

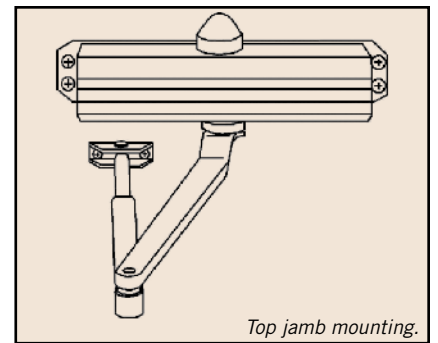

Top jamb mounting.

— Article contributed by Rixson Door Controls.

For more information, contact Rixson Door Controls, an ASSA ABLOY Group company, Telephone: 800-457-5670. Fax: 800-221-0489. Web Site: [www.rixson.com](http://www.rixson.com).

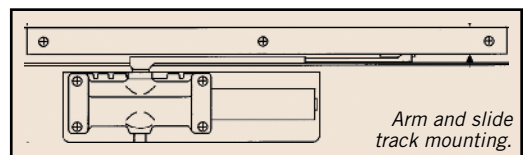

Arm and slide track mounting.