

THE TECHNICAL NEWS MAGAZINE FOR THE SECURITY PROFESSIONAL

LOCKSMITH LEDGER

International

HIGH SECURITY

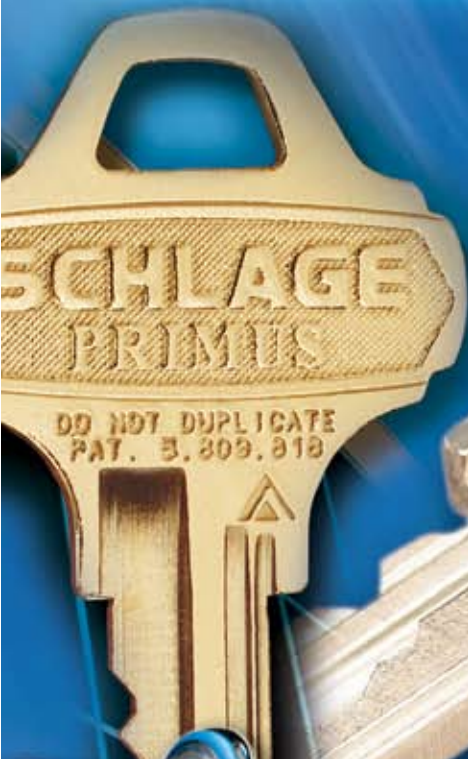

Adding High Security To
Electronic Access Control

Who Owns the Master Key System?

Detex's New EAX-500 & EAX-2500
Standalone Exit Alarms

cygnus
SECURITY GROUP
Delivers Total Coverage of the U.S. Security Industry



MORE TO PIVOTS Than Meets The Eye

BY JERRY LEVINE

The following article is the first in a series discussing pivots, how they function and their interaction with surface mount, concealed and floor closers. This article will address pivot basics.

A pivot is a hinging device incorporating a fixed pin. Pivots are efficient movable joints for attaching a swinging door to a jamb. Unlike hinges, pivots are mounted along the top and bottom of the door. For doors of sufficient size, one or more intermediate pivots are also installed. The bottom pivot supports the entire weight of the door, while the top pivot keeps the door in alignment. Intermediate pivots are designed to help keep the door in alignment and prevent warping.

The basic pivot design is three main components: the leaf of the pivot mounted into the jamb or threshold, the leaf of the pivot mounted into the door, and the pivot stud that interconnects the two pivot portions.

There are two types of pivots – center-hung and offset. Center-hung pivots have their pivot point within door thickness center. An offset pivot has the pivot point located a distance from the heel edge and the face of the door. Center hung pivots are non-handed. They are double-acting, meaning the door can swing both ways if permitted. Offset pivots are always handed, and single acting. Offset pivots are usually easier to adjust than center-hung pivots. Many center-hung pivots require removal of the door to make adjustments.

Typically, offset pivots are available with the pivot



Rixson manufactured door



Top pivot



Top pivot jamb leaf

point 3/4" from the heel edge of the door and 3/4" from the face of the door. This pivot is known as a 3/4" offset pivot. For thicker doors and specialized applications, the pivot point is 3/4" from the heel edge of the door and 1-1/2" from the face. This pivot is known as a 1-1/2" offset pivot.

Pivots come in three basic styles: top pivot, bottom pivot, and intermediate pivot. Unlike hinges, which are interchangeable, each pivot has a specific function and cannot be interchanged. Most top and bottom pivots are installed using screws that are mounted vertically into the door, jamb, and threshold. Screws in this position are less likely to become loose or pull out from the



Top pivot door leaf



Intermediate pivot

opening and closing of a door, make sure that all of the pivots attached to a door are from the same manufacturer.

force exerted by gravity on the door.

Note: The top and intermediate pivots do not support the weight of the door. Only the bottom pivot is designed to support the weight of the door.

Pivots can be manufactured of a variety of metals. Pivots for 20-minute fire doors are non-ferrous. Most pivots are available in a number of finishes to match the finish of the door hardware.

Note: To ensure proper operation of the

Most hollow metal doors are constructed to accommodate either hinges or pivots, by having reinforcement built into the pivot or hinge areas. Most aluminum-glass storefront doors have reinforcement built in for pivots that can also accommodate an overhead concealed closer or a floor closer. For many replacement wood doors, the door rail and stiles have not been machined for either hinges or pivots. If you have any questions, contact the door manufacturer for their recommendations.

The sample door for this article was constructed by Rixson. The offset top pivot is the Rixson Model 180. The offset intermediate pivot is an M19, and the offset bottom pivot is a Model 147. The three Rixson pivots are bronze with hardened metal studs and other components for the pivoting surfaces.

The top and intermediate pivots are each equipped with an Oilite bearing. This oil impregnated bearing surface caps the metal pivot stud. The Oilite bearing is designed to provide a bearing surface for the stud to contact as the door swings keeping the door in proper alignment.

Rixson Model 147 bottom pivots are adjustable. The upper portion of this pivot is composed of a knuckle that is part of the pivot arm that is recessed into the bottom of the door. The arm is usually secured into the door bottom with four or more screws. Into the opening in the center of the arm knuckle mounts the pivot stud.

The specialized pivot stud has a conical-shaped tip with an extended surface around the body of the stud. The pivot stud is mounted into the knuckle from beneath. An arm locking hex screw is tightened to secure the pivot stud in the knuckle.

The pivot stud seats into a sealed thrust bearing raceway that is press fit into the bronze floor mounted plate of the 147. As the door swings open or closed, the bottom pivot stud carries the weight of the door against the thrust bearing. The bearing rotates, turning the door as it swings open and closed.



Intermediate pivot open



Intermediate pivot stud

A properly installed door using a top, intermediate (if present) and bottom pivot should have the following:

1. The door should be plumb, with a uniform clearance between the vertical edges of the door stop and the face of the door of about 1/8".
2. The door should not be warped.
3. The top of the door should clear the jamb, and the bottom of the door should clear the threshold/floor.
4. The leaves of the top and intermediate (if present) should be neither more than 3/16" apart nor tight together. If they are tight together, the intermediate pivot is carrying load of door.

When examining the opening, also check the condition of the door and jamb. For example, aluminum doors can become out of square. Sometimes you will see welds at the connection between the stiles and rails. These welds are probably a result of wind and/or wear damage to the door assembly. At some point in time, instead of replacing the door, a decision was made to weld it back together. If the door is out of square, there are rarely any adjustments for this situation other than welding the door.

Once the door and the jamb have been inspected, check the operation of the door.

Does the door properly close and latch? If not, then the door may require service. There could be a number of problems; however, start with the most benign. Check the location and condition of the weather stripping. Obstructions such as weather strip or a misaligned latch and strike can cause the door to not properly close or latch. Correct any of these conditions first.

The problem could be resolved as simply as tightening the arm locking screw, the mounting screws, or may require replacement of components such as the bottom pivot or more.

This situation can be caused by a number of problems including the arm locking screw becoming loose, building settling, or worn

COMMERCIAL/RESIDENTIAL HARDWARE

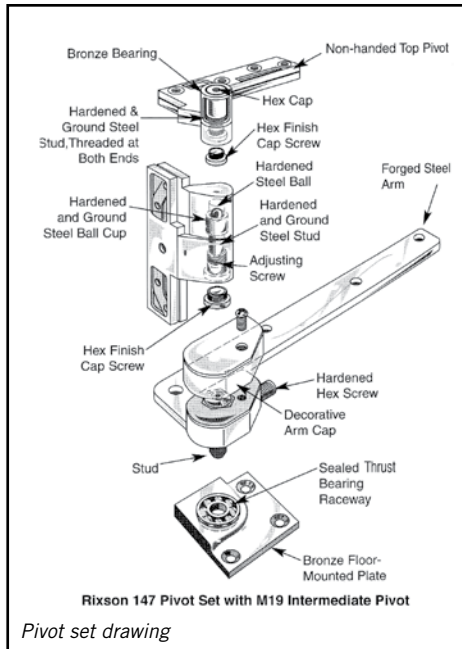

bottom pivot/closer.

The first step is to check the condition of the arm locking screw:

Step 1. Remove the arm cover screw and the arm cover.

Step 2. Open the door slightly.

Step 3. With the door open, lift up and push in on the door. Does the door raise up and/or the arm knuckle slide around the pivot stud? If yes, wiggle the door back and forth while tightening the screw until it is fully seated.

Step 4. Try opening and closing the door. Does the door close and the lock latch? If yes, the problem is solved. However, continue to check the condition of the door.

The next step is to check if the pivots are in adjustment. This can also result in the door dragging along the floor/threshold or



"C" shim installed in bottom pivot

scrape along the header. **To check pivot adjustment:**

Step 1. Open the door and look for signs of dragging or scraping.

Step 2. Close the door and check the alignment within the opening. The gap from the top to the bottom of the door should be approximately the same distance. Usually the gap will vary along the top of the door if the top pivot is worn.

Next, determine if the top pivot needs replacement.

Step 1. Open the door to a slight angle.

Step 2. Place both hands on the latch edge of the door and push inward and upward. If there is any play in the door, the top pivot should probably be replaced. If there is no play in the door, the top pivot is probably in good operating condition.

Check the condition of the bottom pivot.

Open and close the door a number of times. As the door is being closed, does it scrape along the threshold or the header? Does the lock latch when the door closes?

If the door scrapes along the threshold or the header, the door may be out of height adjustment. The door height is determined by the bottom pivot. Most bottom pivots have height adjustment capabilities. The Rixson 147 bottom pivot can be height adjusted using "C" shims. Each of these shims is 1/16" thick. To raise the door height in order to provide the 3/16" clearance between the bottom of the door and the top of the threshold, Rixson uses 1/16" thick "C" shims.

Adjust the height of the door.

Step 1. Remove the arm cap screw from the bottom pivot.

Step 2. Remove the arm cap from the pivot.

Step 3. Loosen the arm locking screw. Loosening the arm lock screw of a Rixson 147 bottom pivot requires a 5/16" hex wrench.

Loosening this screw permits the arm knuckle to be raised by adding "C" shims or lowered by removing shims.

Step 4. To raise or lower the door, use a three- or four-foot crowbar to carefully lift the door. This increases the gap between the arm knuckle and the pivot stud.

To raise the door, slide one or more "C" shims onto the pivot stud between the lip and the knuckle. Check the clearance between the door



From Top to Bottom: Bottom pivot; Cover removed from bottom pivot; Bottom pivot floor mounted plate

and the threshold and the door and the header, then, if the height is correct, tighten the arm locking screw.

To lower the door, remove one or more "C" shims from the pivot stud. Once the height is correct, tighten the arm locking screw.

Future articles will continue the discussion of pivots, including lowering the door, and servicing and maintaining pivots in regards to concealed overhead closers and floor closers.

