



inTouch[®]

Stand-alone Touchscreen Access Cylindrical Lock Installation and Programming Instructions

NOTE TO INSTALLER

FAILURE TO FOLLOW THESE INSTRUCTIONS
COULD RESULT IN DAMAGE TO THE PRODUCT
AND COULD VOID THE FACTORY WARRANTY

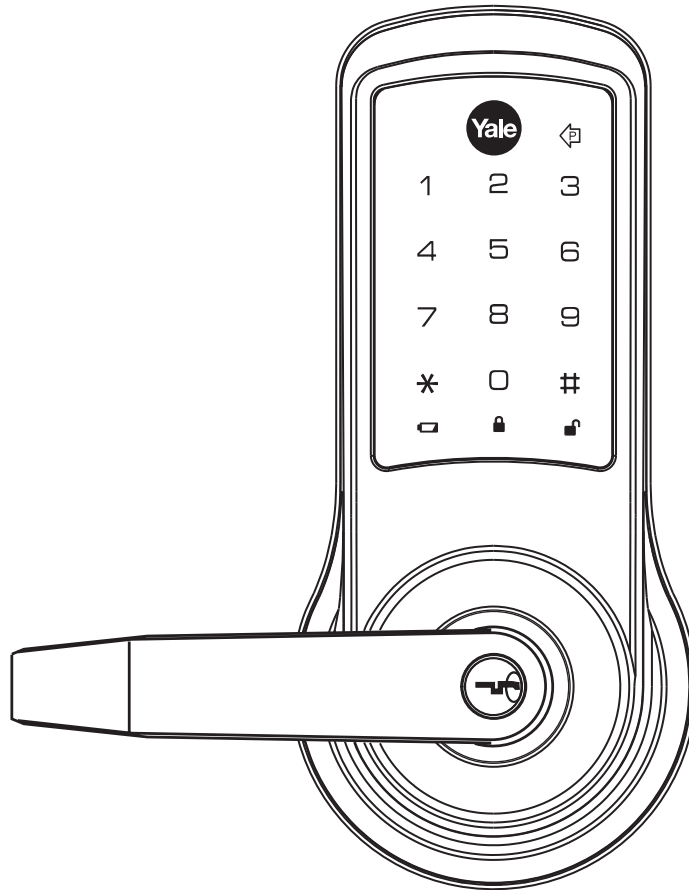

For Technical Assistance call Yale at 1-800-810-WIRE (9473)

This document is available on our website in Spanish and French. Go to www.yalelocks.com.
Click "Product Information & Documentation" and then "Installation Instructions".

Este documento está disponible en español en nuestra página de internet. Vaya a www.yalelocks.com.
Presione "Información del Producto y Documentación" y luego "Instrucciones de Instalación".

Ce document est disponible sur notre site Web dans le français imprimé. Allez à www.yalelocks.com.
Cliquez sur le " ; Information sur le produit et Documentation" et puis " Installation Instructions".



TABLE OF CONTENTS

Warnings	2
Introduction	2
Installation	
Components and Tools	3
Door Preparation	4
Prepare Lock for Installation	5-6
Install Lock	7-8
Hardware Troubleshooting	8
Programming	
Programming Features-Menus-Keys-Definitions	9-11
Operation	12-14
Miscellaneous Information	14
Programming Troubleshooting	15
Sample Pin Code Management Sheet	16-19

WARNINGS

CAUTION: Changes or modifications to this unit not expressly approved by the party responsible for compliance could void the user's authority to operate the equipment.

IMPORTANT: The accuracy of the door preparation is critical for the proper functioning and security of this cylindrical product. Misalignment can cause premature wear and a lessening of security.

Finish Care: This lockset is designed to provide the highest standard of product quality and performance. Care should be taken to ensure a long-lasting finish. When cleaning is required use a soft, damp cloth. Using lacquer thinner, caustic soaps, abrasive cleaners or polishes could damage the coating and result in tarnishing the finish.

Attention Installer: Any retrofit or other field modification to a fire rated opening can potentially impact the fire rating of the opening, and Yale Locks & Hardware makes no representations or warranties concerning what such impact may be in any specific situation. When retrofitting any portion of an existing fire rated opening, or specifying and installing a new fire-rated opening, please consult with a code specialist or local code official (Authority Having Jurisdiction) to ensure compliance with all applicable codes and ratings.

INTRODUCTION

Yale® inTouch® Stand-alone Touchscreen Access Lock combines robust cylindrical locksets with a contemporary electronic aesthetic.

Users benefit from an interactive touchscreen that makes day-to-day access effortless and offers voice-guided programming for simple updates to user information in the event of staffing changes or security breaches.

inTouch is engineered for quick & easy installation and fits into the standard ANSI/BHMA A156.115 cylindrical locks with lever door prep with only one additional 3/4" hole and 7 screws including latchbolt and strike.

INSTALLATION

COMPONENTS AND TOOLS

In the box, you should find...

Quick Start Instructions

Installation Instructions

Door Marker

Outside Touchscreen Assembly

Inside Escutcheon Assembly:

- Inside Support Assembly
- Inside Escutcheon
- Inside Lever Handle
- Battery Cover

4 AA Alkaline Batteries

Latchbolt

Strike

Allen Wrench 3/32" (2.5mm)

Lever Removal Tool

Screw Pack (7 screws)

2 Keys (If cylinder included)

Parts Illustrations

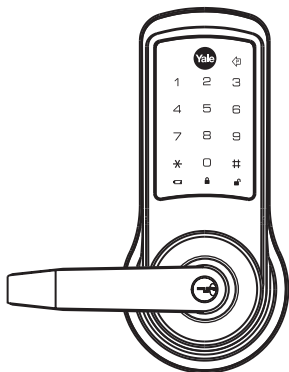

Outside
Touchscreen
Assembly

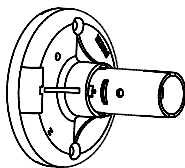

Inside
Support
Assembly

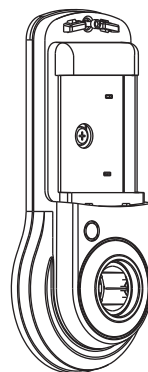

Inside
Escutcheon

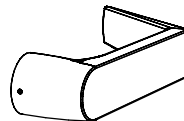

Inside
Lever
Handle

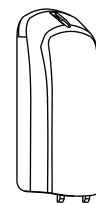

Battery Cover
4 AA Alkaline
Batteries

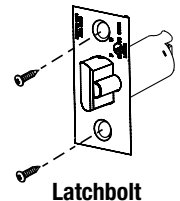
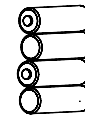

Latchbolt

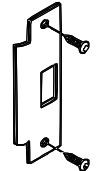

Strike

Tools

Door Prep

- 2-1/8" (54mm) hole saw
- 1" (26mm) boring bit
- 3/4" (19mm) drill bit
- 5/16" (8mm) drill bit
- 7/64" (2.5mm) drill bit
- Chisel & hammer
- 3/8" or 1/2" drill

Lock Installation

- #2 phillips screw driver
- Lever removal tool (supplied)
- 3/32" Allen wrench (supplied)

DOOR PREPARATION

Mark Door

Verify backset before marking and drilling door.

- A. Mark horizontal line across edge of door at desired lever installation height.
- B. Fold door marker over the edge of the door, centering on the horizontal line.
- C. Mark centers of holes at proper backset. For beveled and square edge doors, mark both sides of the door.

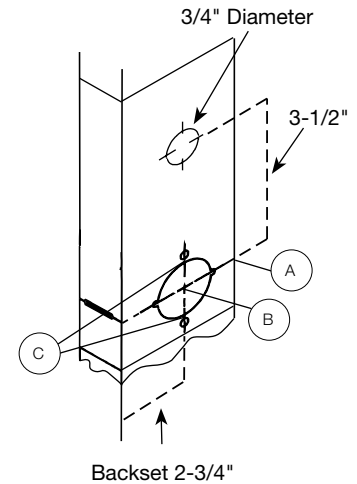

Drill Door

- A. Drill 2-1/8" (54mm) dia. hole through the door. Cut notches as shown on template.

Note: To avoid splintering wood doors, drill holes (A), (B) and (D) from both sides of the door.
- B. Drill 3/4" (19mm) diameter hole through the door according to door marker. (See note above.)
- C. Drill 1" (25mm) diameter hole in edge of door. Mortise for latchbolt front 1-1/8" (29mm) wide x 2-1/4" (57mm) high by 5/32" deep.
- D. Drill two (2) 5/16" (8mm) diameter holes through door (see note, above).
- E. Drill pilot holes for latchbolt screws. 7/64" (2.5mm).

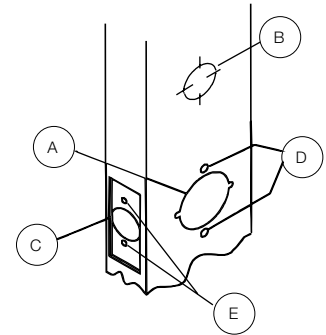

Prepare and Install Strike (Wood Frames Only)

- A. Close the door and mark a horizontal line from the center of the template to the frame of the door.
- B. Measure half the thickness of the door. Mark this same distance with a vertical line starting from the stop side of the frame. Where both lines cross make a 1" (25mm) diameter hole, 1/2" (13 mm) in depth.
- C. Align the holes of the strike with the vertical line. Trace the outline of the strike and mortise with a 1/16" (1.6mm) depth. Attach the strike with two screws (provided).

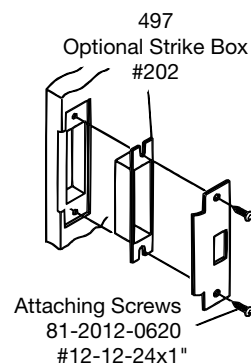
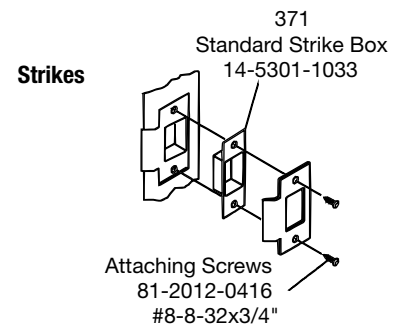

PREPARE LOCK FOR INSTALLATION

Unpack the Lock

The lock is packed representative of how it will install on the door.

Before installation:

A. Disassemble the inside escutcheon

1. Remove the inside lever with the lever removal tool provided
2. Separate the inside support assembly from the inside escutcheon

B. Remove the battery cover

1. Unscrew the hex screw using the Allen wrench provided. The hex screw does not come completely out.
2. Slide the battery cover off.

The outside assembly stays assembled.

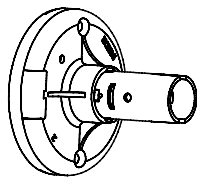

Inside
Support
Assembly

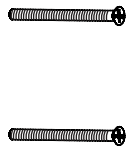

Support
Assembly
Screws

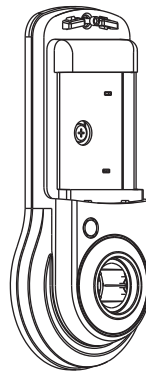

Inside
Escutcheon

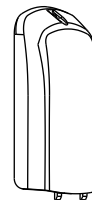

Battery
Cover

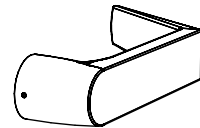

Inside
Lever
Handle

Determine Hand of the Door

Face the door from the secure side to determine it's hand.

The secure side is the touchscreen side of an entrance door or the corridor side of a room door.

Note: inTouch locks are non-handed; the lever can be flipped around to the desired handing.



Left Hand Reverse

Hinges on left.
Opens outward.
For handed locks,
specify LHR.



Left Hand

Hinges on left.
Opens inward.
For handed locks,
specify LH.



Right Hand

Hinges on right.
Opens inward.
for handed locks,
specify RH.



Right Hand Reverse

Hinges on right.
Opens outward.
For handed locks,
specify RHR.

How to Replace, Re-Key or Install Cylinder

1. Remove cylinder handle:
 - A. Insert key and rotate 45 degrees counterclockwise.
 - B. Insert lever retainer tool and push.
 - C. Slide lever off lock.
2. Remove the plastic sleeve from the old cylinder.
3. Slide new cylinder into sleeve.
4. Insert key into cylinder.

Important: Make sure the key cut side of key lines up facing towards the end of the lever. If the key is inserted incorrectly, the lock will reassemble and might appear to properly work; however, when the key is removed, the latchbolt will remain retracted.

5. Rotate key 45 degrees counterclockwise.

Depress retainer plate, push the handle onto the shank until fully seated.
Pull on handle to insure properly seated.

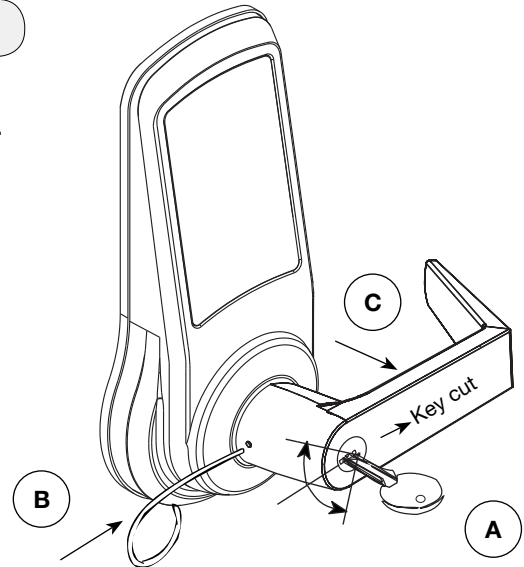

CAUTION: For units shipped prior to March 2012: The cylinders furnished with inTouch® lock for use in 1-3/8" doors have a tailpiece that is 1/4" shorter than the standard cylinders that are furnished for 1-3/4" doors. Trying to install a standard cylinder in locksets designed for 1-3/8" doors will **DAMAGE** the lock body.

Adjust for Door Thickness (If Necessary)

Lock is provided standard for use on 1-3/4" thick doors. For use on 1-3/8" thick doors, special thin door kit must be used. To order 1-3/8" thin door kit, specify part number 14-4761-0106. This kit includes inside and outside escutcheon spacers as well as a 2-3/8" latchbolt. Note: using a 2-3/8" latchbolt results in Grade 2 certification on the lock.

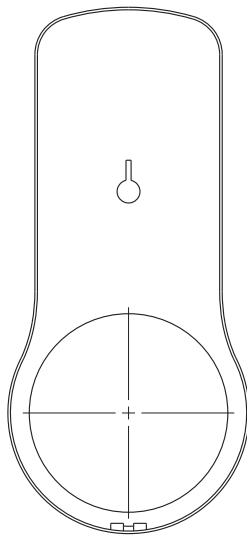

Outside Keypad Escutcheon Gasket

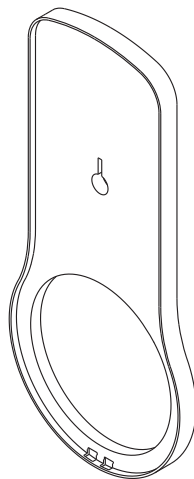

Inside Escutcheon Gasket

INSTALL LOCK

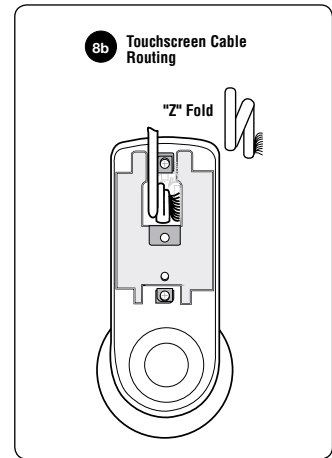
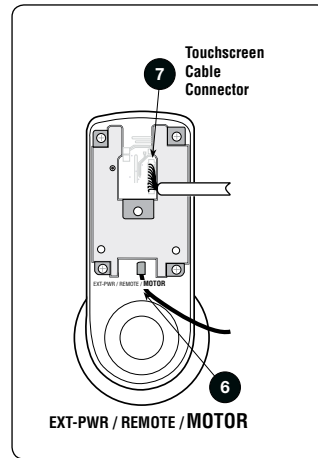
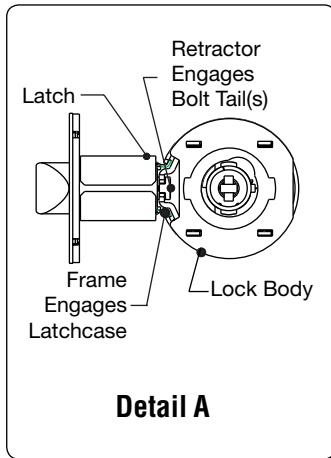
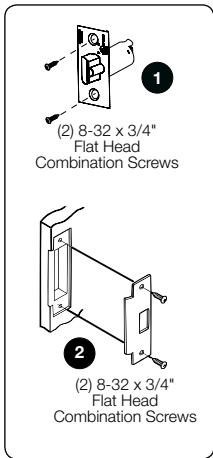
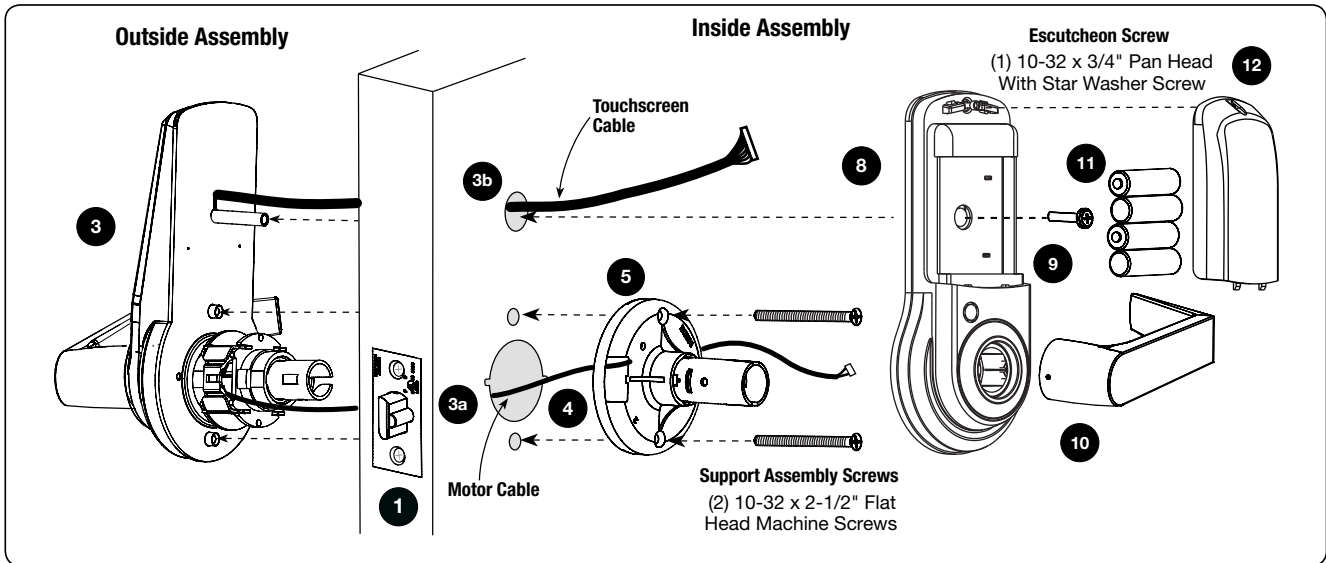

Directions

1. Install latchbolt in door. Be sure that bevel edge of bolt faces strike. Attach with two screws supplied.
2. Install strike on the door frame.
3. Insert outside assembly through door, making sure that the lock body frame hooks latch case and retractor engages bolt tail(s). **DO NOT FORCE** (See Detail A above). If lock body does not engage latch easily, check door preparation for errors.
 - a. Guide motor cable (red and black wires) through 2-1/8" diameter hole.
 - b. Guide touchscreen cable through 3/4" diameter upper hole.
4. Guide motor cable through rectangular hole on inside support assembly.
5. Slide inside support assembly over outside assembly, lining up top and bottom screw guides with holes in door. Secure both assemblies with (2) 10-32 x 2-1/2" flat head machine screws. Do not over-tighten.
6. Attach motor cable connector to the inside escutcheon PC board header marked "MOTOR."
7. Attach the touchscreen cable connector to the inside escutcheon PC board header as illustrated.

Directions, Continued

8. Slide inside escutcheon over inside support assembly.

CAUTION:

- a. Position motor cable against inside support assembly. Avoid pinching wires against the steel shank of the assembly.
- b. "Z" fold touchscreen wire cable and lay against the back recessed area of the escutcheon assembly. Position and bend wires to prevent binding when installing the escutcheon over the support assembly.

9. Install and secure the 10-32 x 3/4" pan head screw through the center of the battery housing into the barrel nut of the outside assembly.

10. Slide on inside lever and push in to attach.

11. Insert four (4) AA alkaline batteries. The lock responds, "Welcome to the Yale Digital World."

12. Install battery cover and tighten hex head screw with Allen wrench provided with lock.

HARDWARE TROUBLESHOOTING

Test the Operation of the Mechanical Lockset

Cycle the lock in both the locked and the unlocked positions. If problems are found:

Symptom	Suggested Action
Door is binding	<ol style="list-style-type: none">a. Check that door and frame are properly aligned and door is free swinging.b. Check hinges: They should not be loose or have excessive wear on knuckles.
Latchbolt will not deadlock	<ol style="list-style-type: none">a. Either strike is out of alignment or the gap between the door and jamb is too great. Realign strike or shim strike out towards flat area of latchbolt.
Latchbolt does not retract or extend properly	<p>Latchbolt tail and retractor are not properly positioned:</p> <ol style="list-style-type: none">a. Remove lockset. Look through 2-1/8" hole and verify latchbolt tail is centered between top and bottom of hole.b. Remove latchbolt and insert lockset. Look through latchbolt hole and verify retractor mouth centered in hole. If not, adjust outside rose plate.c. If necessary, rebore holes to line up retractor and tail.

PROGRAMMING

Programming Features-Menus-Keys-Definitions	9-11
Operation	12-14
Miscellaneous Information	14
Programming Troubleshooting	15
Sample Pin Code Management Sheets	16-19

PROGRAMMING FEATURES - MENUS - KEYS - DEFINITIONS



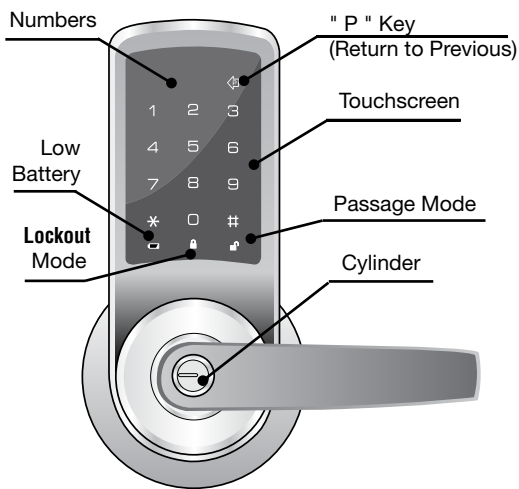



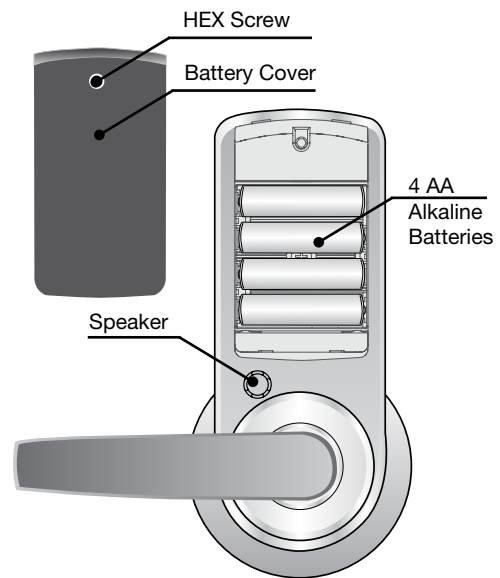





Outside



Inside



Menu and Icons

	Touch the screen with palm of hand or fingers to begin and end actions.		Enter Personalized Master PIN code (6 digits in length).
	Click the indicated number.		Enter User PIN. Can be 4-12 digits in length.
	Press the Star key on the touchscreen to Enter or Accept entry.		User Number (1 - 255).
	Press the Pound key on the touchscreen to enter Menu mode.		Enter value 1 - 10 (times or seconds).
	Press this key to return to the previous step or menu setting.		Enter value 1 - 255 (seconds).
	Repeat operation using settings indicated.		Voice guide.
	Slide the battery cover up and off.		

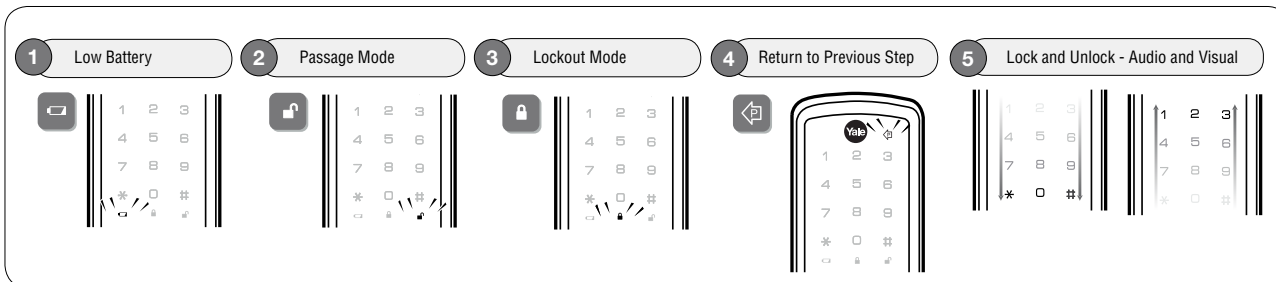

Definitions

All Code Lockout: This feature is enabled only by the Master code. When enabled, it restricts all user PIN code access. When the unit is in Lockout, the red locked padlock will appear on the screen.

Low Battery: When battery power is low, the low battery icon will begin blinking. If battery power is completely lost, the key and cylinder can be used.

Passage Mode: Enabling Passage mode allows continuous entry for non-restricted traffic. Passage mode is enabled or disabled through feature programming by the Master code. When the unit is in Passage Mode, the green unlocked padlock will appear on the screen.

Master Code: The Master code is personalized by the user upon installation. There is no factory default. The Master code is used for programming User codes and feature settings. The Master code will operate the lock.

Definitions

Re-lock Time: After successful code entry and the unit unlocks, it will automatically re-lock after a default of five (5) seconds. Re-lock time is adjustable from one (1) to ten (10) seconds through feature settings.

Shut Down Time: The unit will shut down for a default of one hundred and eighty (180) seconds and not allow operation after the wrong code entry limit has been met. Shut down time is adjustable from one (1) to two hundred and fifty-five (255) seconds through feature settings. When the unit is in Shut Down, the red locked padlock icon will be flashing.

Silent Mode: Enabling Silent mode shuts off the code confirmation tone playback for use in quiet areas. Silent mode is enabled or disabled through feature programming by the Master code.

User Code: The User code is used for operating the lock.

User Lockout: This feature is enabled by the Master code. When enabled, it restricts User PIN code access only for the specified User numbers.

Wrong Code Entry Limit: After a default of five (5) unsuccessful attempts at entering a valid PIN code the unit will shut down and not allow operation. Wrong code entry limit is adjustable from one (1) to ten (10) times through feature settings.

OPERATION

inTouch® features single programming mode with a total of 255 PIN codes available for access. All programming is performed through the touchscreen by use of the Master code (which also grants access) and voice guided prompts.

The lock can be programmed for Passage mode, Silent mode, Lockout mode or alternate language settings. Auto re-lock time, wrong code entry limits and shut down times are adjustable can be changed from factory default.

Settings	Master	User
Entrance Authorization	x	x
Register/Change Master Code	x	
Register/Change/Delete User Code	x	
Set All Code Lockout Mode	x	
Set User Lockout Mode	x	
Set Passage Mode	x	
Set Silent Mode	x	
Set Re-lock Time	x	
Set Wrong Code Entry Limit	x	
Set Shut Down Time	x	
Set Language Setting Mode	x	

Settings	Factory Defaults
Master Code	User Personalized
Lockout Mode	Disabled
Passage Mode	Disabled
Silent Mode	Disabled
Re-lock Time	5 Seconds
Wrong Code Entry Limit	5 Times
Shut Down Time	180 Seconds
Language	English

Operation of Lock

Touch lock with palm of hand or fingers to activate.

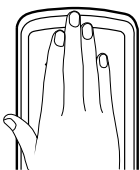

Enter the Master or a User PIN code.

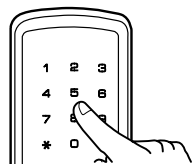



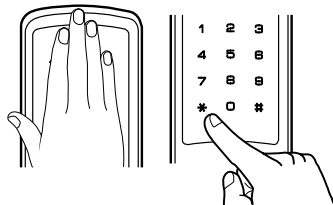

Palm touch the screen or press the * key to confirm the selection.

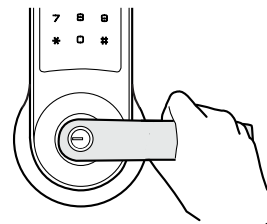





Turn lever to open door.



Establish the Master Code Before Programming

1. Touch the screen with the palm of your hand or fingers to activate .
2. Press the  key.
3. Enter personalized 6-digit Master PIN code followed by the  key.
4. Press  key to complete the process and conclude the programming session.

Feature Programming

1. Touch the screen with the palm of your hand or fingers to activate .
2. Enter the 6-digit Master PIN code followed by the  key.
Lock Response: "Menu mode, enter number, press the  key to continue."
3. Enter digit corresponding to the function to be performed followed by the  key.
Follow the verbal commands.
4. Press the  key to complete the process and conclude the programming session.

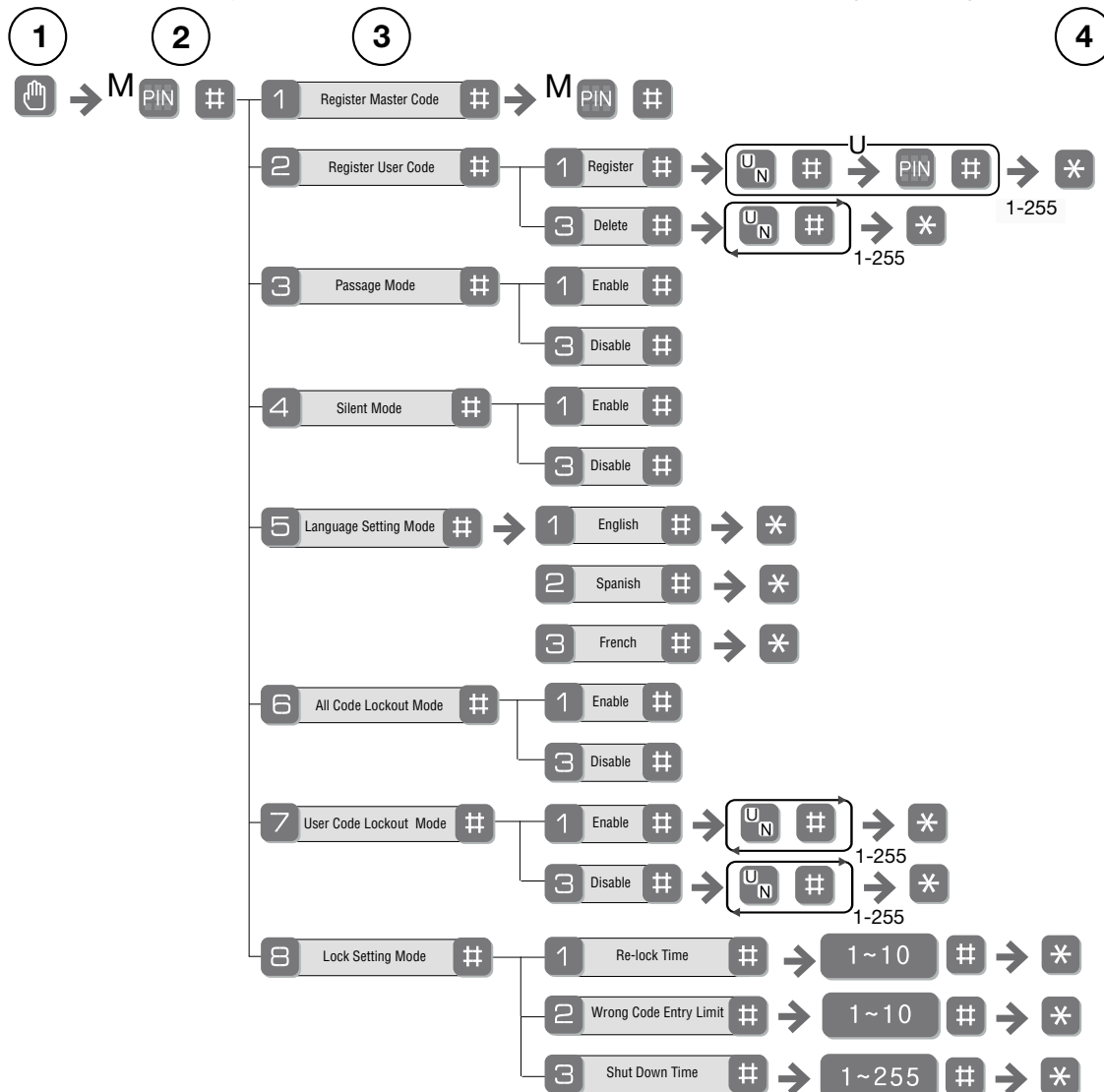

To Set Up User Codes

User Codes can only be programmed through Master Code.

1. Touch the screen with the palm of your hand or fingers to activate .

2. Enter the 6 digit Master PIN code followed by the  key.

Lock Response: "Menu mode, enter number, press the  key to continue."

3. Enter "2" followed by the  key.

4. Enter "1" followed by the  key.

5. Enter the User number to be registered (1-255) followed by the  key.

6. Enter a 4-12 digit PIN code for the User number followed by the  key.

Press  to add more users.

7. Press the  key to complete the process and conclude the programming session.

MISCELLANEOUS INFORMATION

Returning the Lock to Factory Defaults

The outside assembly remains assembled.

1. Remove inside lever with the lever removal tool.
2. Remove battery cover using Allen wrench provided with lock.
3. Remove four (4) AA alkaline batteries.
4. Remove the 10-32 x 3/4" pan head screw from the center of the battery housing into the barrel nut of the outside assembly.
5. Remove inside escutcheon.
6. Reinstall batteries four (4) AA alkaline batteries.
7. On the back of the PC board, push and hold the Reset Button with the lever removal tool for 3 seconds.
8. Temporarily remove one (1) AA battery (still holding the reset button in).
9. Reinstall the AA battery (still holding the reset button in).
10. Release reset button and wait 3 seconds.
11. The speaker will announce "Welcome to the Yale Digital World".

To reassemble the lock, refer to steps 8 through 12 on page 8.
All programming should be returned to factory defaults.

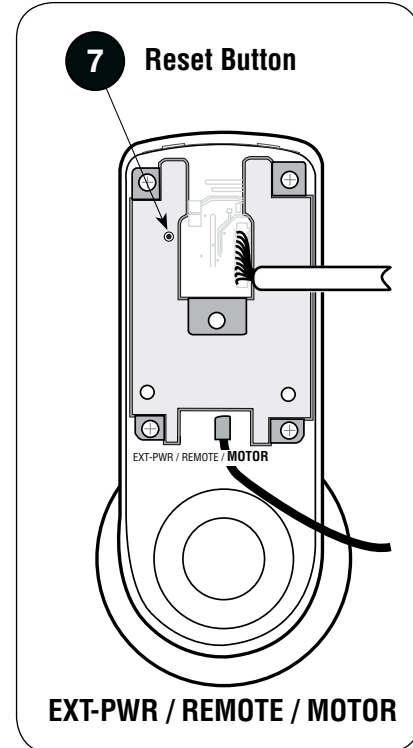

PROGRAMMING TROUBLESHOOTING

Symptom	Suggested Action
Lock does not respond – door is open and accessible.	<ul style="list-style-type: none"> • The touchscreen will become active when pressed with the palm or fingers in at least 3 areas simultaneously. <ul style="list-style-type: none"> • Use a larger area of the palm or fingers and verify contact with at least 3 areas. • If touchscreen numbers are visible, check to see if they respond when pressed. • Check batteries are installed and oriented correctly in the battery case. • Check batteries are in good condition; replace batteries if discharged. • Check to see if touchscreen cable is properly connected and not pinched (page 7).
Lock does not respond – door is locked and inaccessible.	<ul style="list-style-type: none"> • Batteries may be completely discharged. <ul style="list-style-type: none"> • Use mechanical key to gain entry and replace batteries.
The unit is on for a while, and then shows no reaction. Lights dim.	<ul style="list-style-type: none"> • The batteries do not have enough power. Replace the batteries.
Unit chimes to indicate code acceptance, but the door will not open.	<ul style="list-style-type: none"> • Check to see if there is another locking device on the door (i.e. deadbolt). • Check the door gaps for any foreign objects between door and frame. • Check that the motor cable is firmly connected to the PC board header marked “MOTOR” (page 7).
Unit operates to allow access, but will not automatically re-lock.	<ul style="list-style-type: none"> • Check to see if Passage Mode is enabled. <ul style="list-style-type: none"> • If the Passage Mode icon on the touchscreen and the status indicator on the interior escutcheon flicker for several seconds, it is set at Passage Mode (page 10). • Disable Passage Mode to lock the door. • If low battery indicator is lit (page 10), change batteries.
PIN codes will not register.	<ul style="list-style-type: none"> • PIN codes must consist of 4 to 12 digits to register. • The same PIN code cannot be used for multiple users. • Registration/management of PIN codes is set at the authority of the Master. <ul style="list-style-type: none"> • Contact the Master. • The Master PIN code does unlock the door. • User codes must be entered within 20 seconds (while the touchscreen is active) or the process will have to be restarted. • The star (*) or pound (#) can not be used as part of the PIN code.
Upon entering a PIN code and pressing the star (*) key, the unit displays and “invalid code” error or the lock times out without responding.	<ul style="list-style-type: none"> • Either All Code or User Lockout Mode is enabled (pages 13). • Only the Master can enable Lockout Mode. <ul style="list-style-type: none"> • Contact the Master user.
Upon entering a PIN code and pressing the (*) key, the red padlock icon appears and there are different tones.	<ul style="list-style-type: none"> • Check to see if you are set at Lockout Mode. • Setting/managing Lockout Mode is up to Master. Contact the Master.
The unit operates, but it makes no sound.	<ul style="list-style-type: none"> • Check to see if Silent Mode is enabled (page 13).
The unit responds “Low Battery”	<ul style="list-style-type: none"> • This is the voice alarm alerting that it is time to replace the batteries. Replace all four (4) batteries with new AA Alkaline batteries.
Upon entering a PIN code and pressing the star (*) key, the unit responds “Wrong digit numbers.”	<ul style="list-style-type: none"> • The digits entered were incorrect or incomplete. Re-enter the code.

PIN CODE MANAGEMENT SAMPLE SHEETS

PIN Code Management					
Door Number:			Door Number:		
	User Name	PIN Number		User Name	PIN Number
	User 1			User 41	
	User 2			User 42	
	User 3			User 43	
	User 4			User 44	
	User 5			User 45	
	User 6			User 46	
	User 7			User 47	
	User 8			User 48	
	User 9			User 49	
	User 10			User 50	
	User 11			User 51	
	User 12			User 52	
	User 13			User 53	
	User 14			User 54	
	User 15			User 55	
	User 16			User 56	
	User 17			User 57	
	User 18			User 58	
	User 19			User 59	
	User 20			User 60	
	User 21			User 61	
	User 22			User 62	
	User 23			User 63	
	User 24			User 64	
	User 25			User 65	
	User 26			User 66	
	User 27			User 67	
	User 28			User 68	
	User 29			User 69	
	User 30			User 70	
	User 31			User 71	
	User 32			User 72	
	User 33			User 73	
	User 34			User 74	
	User 35			User 75	
	User 36			User 76	
	User 37			User 77	
	User 38			User 78	
	User 39			User 79	
	User 40			User 80	

PIN CODE MANAGEMENT SAMPLE SHEETS

PIN Code Management					
Door Number:			Door Number:		
	User Name	PIN Number		User Name	PIN Number
	User 81			User 121	
	User 82			User 122	
	User 83			User 123	
	User 84			User 124	
	User 85			User 125	
	User 86			User 126	
	User 87			User 127	
	User 88			User 128	
	User 89			User 129	
	User 90			User 130	
	User 91			User 131	
	User 92			User 132	
	User 93			User 133	
	User 94			User 134	
	User 95			User 135	
	User 96			User 136	
	User 97			User 137	
	User 98			User 138	
	User 99			User 139	
	User 100			User 140	
	User 101			User 141	
	User 102			User 142	
	User 103			User 143	
	User 104			User 144	
	User 105			User 145	
	User 106			User 146	
	User 107			User 147	
	User 108			User 148	
	User 109			User 149	
	User 110			User 150	
	User 111			User 151	
	User 112			User 152	
	User 113			User 153	
	User 114			User 154	
	User 115			User 155	
	User 116			User 156	
	User 117			User 157	
	User 118			User 158	
	User 119			User 159	
	User 120			User 160	

PIN CODE MANAGEMENT SAMPLE SHEETS

PIN Code Management					
Door Number:			Door Number:		
	User Name	PIN Number		User Name	PIN Number
	User 161			User 201	
	User 162			User 202	
	User 163			User 203	
	User 164			User 204	
	User 165			User 205	
	User 166			User 206	
	User 167			User 207	
	User 168			User 208	
	User 169			User 209	
	User 170			User 210	
	User 171			User 211	
	User 172			User 212	
	User 173			User 213	
	User 174			User 214	
	User 175			User 215	
	User 176			User 216	
	User 177			User 217	
	User 178			User 218	
	User 179			User 219	
	User 180			User 220	
	User 181			User 221	
	User 182			User 222	
	User 183			User 223	
	User 184			User 224	
	User 185			User 225	
	User 186			User 226	
	User 187			User 227	
	User 188			User 228	
	User 189			User 229	
	User 190			User 230	
	User 191			User 231	
	User 192			User 232	
	User 193			User 233	
	User 194			User 234	
	User 195			User 235	
	User 196			User 236	
	User 197			User 237	
	User 198			User 238	
	User 199			User 239	
	User 200			User 240	

PIN CODE MANAGEMENT SAMPLE SHEETS

PIN Code Management		
Door Number:		
	User Name	PIN Number
User 241		
User 242		
User 243		
User 244		
User 245		
User 246		
User 247		
User 248		
User 249		
User 250		
User 251		
User 252		
User 253		
User 254		
User 255		

ONLINE LITERATURE AND TEMPLATES

For the latest information on Yale products visit our website at www.yalelocks.com. Click on the “Literature” button to find the most up-to-date catalogs, parts manuals, templates, specifications and installation instructions.

Look for eBUSINESS and click on it to register for an ebusiness account.

Yale Locks & Hardware

Product Support Tel 1-800-810-WIRE (9473) • www.yalelocks.com

Yale Locks & Hardware is a division of Yale Security Inc., an ASSA ABLOY Group company.

Yale® and inTouch® are registered trademarks of Yale Security Inc., an ASSA ABLOY Group company. Other products' brand names may be trademarks or registered trademarks of their respective owners and are mentioned for reference purposes only. These materials are protected under U.S. copyright laws. All contents current at time of publication.

Yale Security Inc. reserves the right to change availability of any item in this catalog, its design, construction, and/or its materials.

Copyright © 2012, Yale Security Inc., an ASSA ABLOY Group company.

All rights reserved. Reproduction in whole or in part without the express written permission of Yale Security Inc. is prohibited.